

# IGN-1A Smart Coil User Guide

Link Part Number 101-0291

## Wiring:

Viewed looking into connector on coil

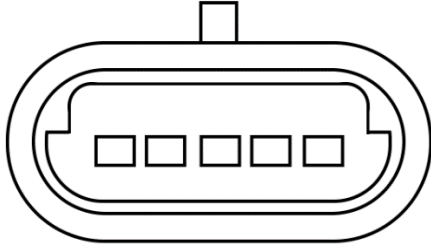

**A B C D E**

- A. ECU Ignition Output
- B. Ground to Main ECU Ground Point (usually engine block)
- C. Ground to Cylinder Head
- D. Battery Negative
- E. +12V from Ignition Switched Relay

Pins D & E can pull high current in extreme applications, consult the chart at the end of this document for approximate expected peak current. For typical performance road car engines only about 3ms dwell will be required, therefore 20 or 18AWG wire will generally be adequate. For high boost/high power/alcohol applications however the current and voltage requirement increases significantly so more thorough considerations need to be made, these are discussed in more detail in the section below titled "Further Considerations for Very High-Power Applications". The connector terminals are suitable for 16-20AWG wire.

For V or boxer engines, Pin C ground wire should be connected to the same cylinder head that the connected spark plug is fitted to. For rotary engines connect Pin C to the rotor housing that the relevant sparkplug is fitted to.

The mating connector plug for this coil is a slightly unusual "pull-to-seat" type, this requires the unterminated wire to be pushed all the way through the plug housing first, then the terminal is crimped on before pulling the wire and terminal back into the housing.

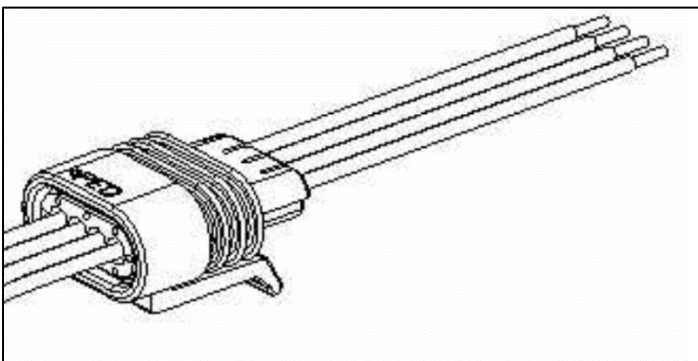

Step 1: Feed unterminated wires through plug, strip 4.5mm of insulation.

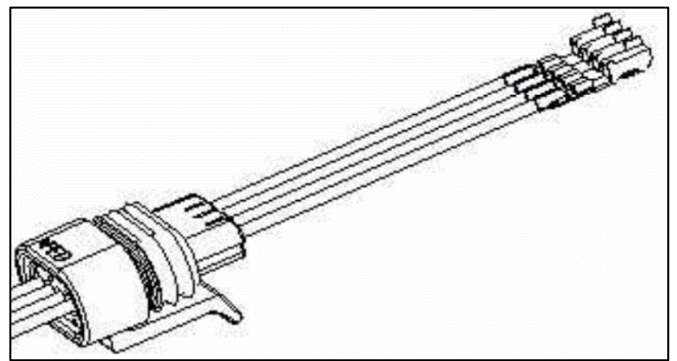

Step 2: Crimp terminals using appropriate crimp tool

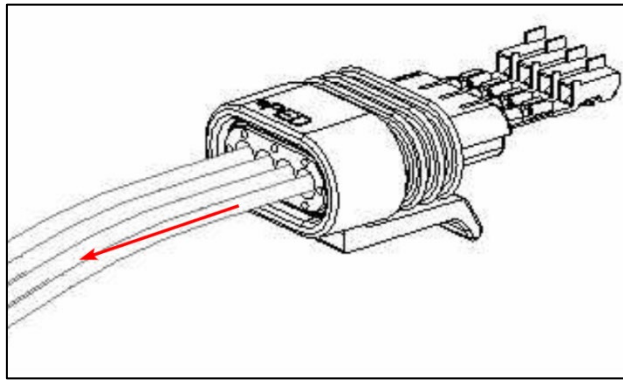

Step 3: Pull wires back until terminals click into plug housing.

### ***Considerations for All Applications:***

Mount coils as close as possible to the spark plug, but with some consideration of heat exposure. In road cars avoid mounting near sensitive electronics such as the engine ECU or ABS ECU and avoid running HT leads parallel to adjacent sensitive signal wires such as crank sensor wires. Use good quality spiral wound suppressed HT leads with tight fitting boots. Use resistor spark plugs. For most applications keep the spark plug gap around a nominal ~ 0.7mm to minimise EMI and maximise spark duration.

### ***Further Considerations for Very High–Power Applications:***

As combustion pressures increase the required spark voltage to jump the spark plug gap will increase. These coils are capable of generating very high energy, but for the most demanding applications (say >200HP/Cyl), there are many other related factors that need to be well planned to make sure this high energy does actually make it to the spark plug gap reliably, and with minimal side effects.

Wiring: To achieve the expected performance, the power supply wires to pins D & E must be capable of carrying the peak current (not just the average) with minimal voltage drop, select quality wire of adequate gauge, keep the total length as short as possible and minimise joints/splices/connectors in the power supply path. Use a quality relay(s) with low contact resistance.

Spark Leakage: At the highest power levels, all precautions to eliminate spark leakage are required – Spark plug and coil boots must be a snug fit and extend all the way down the spark plug porcelain. Boots and leads and the environment around the spark plug needs to be clean and dry – especially where the spark plug is down inside a well. Use liberal application of dielectric grease on the inside of the HT lead rubber boots where they meet the sparkplug and coil tower.

### ***Operating Recommendations:***

General Manufacturer Recommendations:

Maximum continuous duty cycle: 40%

Maximum short term duty cycle: 80% (short bursts <5s with some cooling time between bursts).

Maximum dwell time @14V: 9ms.

Maximum primary current: 20A.

Spark Edge: Falling.

## Dwell Recommendations:

The manufacturers recommended maximum continuous duty cycle of 40% can easily be exceeded with some engine configurations – this is especially true with wasted spark ignition, distributor ignition and rotary engines, therefore this should always be calculated and considered when building or adjusting the dwell table. Always use the minimum dwell time necessary, only increase if there is a misfire due to a lack of ignition energy. If the maximum recommended 40% duty cycle needs to be exceeded then set up the dwell table with either boost pressure or RPM on one axis so that the duty cycle limitation is only exceeded under conditions where it is absolutely needed such as at high boost or around the peak torque RPM band.

To calculate coil duty cycle from the commanded dwell time the following formulas can be used:

- Four stroke direct spark:  $Duty\ cycle(\%) = Dwell(mS) \times RPM/1200$ .
- Two stroke direct spark, Rotary direct spark, Four stroke wasted spark:  $Duty\ cycle(\%) = Dwell(mS) \times RPM/600$ .
- Four Stroke Distributor Ignition:  $Duty\ cycle(\%) = Dwell(mS) \times Number\ of\ cylinders \times RPM/1200$ .

## Example Dwell Tables:

Basic table suitable for typical performance road cars. The coil will draw about 5A regardless of batt voltage:

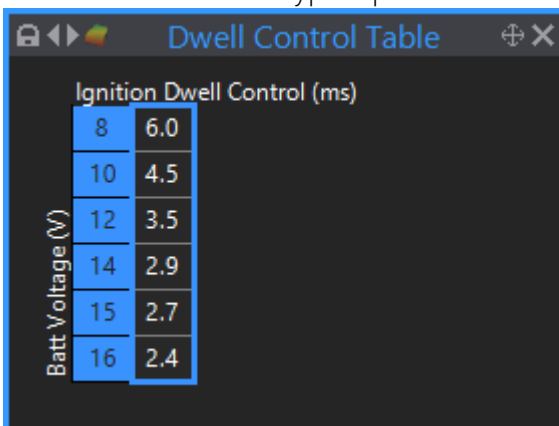

Ignition Dwell Control (ms)	
8	6.0
10	4.5
12	3.5
14	2.9
15	2.7
16	2.4

High boost alcohol drag engine. The Y axis is added referencing MGP. The maximum duty cycle will only be exceeded for the short time spent above 550Kpa and about 8000RPM:



Batt Voltage (V)	Ignition Dwell Control (ms)					MGP (kPa)				
	0	300	400	500	550	0	300	400	500	550
12	3.5	3.5	6.5	7.0	8.0					
14	2.9	2.9	6.5	7.0	8.0					
15	2.7	2.7	5.3	6.5	7.0					
16	2.4	2.4	4.6	5.5	6.0					
18	2.2	2.2	4.0	4.5	5.0					

*Approximate Current Draw Vs Dwell:*

